



# OWNER'S MANUAL

POWER PROCEDURE CHAIR

4010-650

4011-650

5016-650



SERIAL NUMBER

DATE OF MANUFACTURE

MAXIMUM PATIENT WEIGHT      650 LBS / 295 KG

# IMPORTANT INFORMATION

Safety First: This equipment must be operated and maintained with the safety of the patient and doctor in mind.

- 1 Read this manual before operating your new UMF Medical equipment.
- 2 This product is intended to be used for positioning of patients during medical examinations conducted by qualified medical personnel.
- 3 This manual should remain permanently affixed or near the equipment for convenient reference.
- 4 UMF Medical reserves the right to make changes to the design of products at any time and without notice.

# INTENDED USE

This table is intended for patients weighing no more than 650 lbs /295 kg distributed evenly over the entire table surface.

Patient should be evenly supported over the entire table length.

Back rest is not intended to be used as a seat or to support entire patient weight. Use of the back rest as a seat or to support entire patient weight is considered misuse and may cause back to fail causing potential injury.

# CLASSIFICATIONS

## Equipment Class – Class I

Protection against electric shock: Type B applied parts

Protection against harmful ingress of water: Ordinary Equipment is not suitable for use in the presence of a flammable anesthetics mixture with air or with oxygen or with nitrous oxide .

Mode of Operation: Continuous operation with intermittent loading 1 minute on 9 minutes off or 2 minutes on, 18 minutes off.

This product has been evaluated with respect to electrical shock, fire, & mechanical hazards only, in accordance with UL60601-1 and CAN/CSA-22.2 No. 601.1

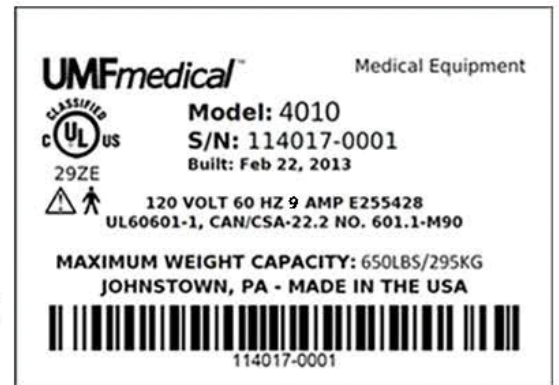

\* Label found on back of table

# SAFETY SYMBOLS

**WARNING:** The warning symbol identifies special instructions or procedures, which if not correctly followed could result in personal injury.

**CAUTION:** The caution symbol identifies special instructions or procedures, which if not properly followed could result in danger or damage to equipment.



UL CLASSIFICATION MARK WITH RESPECT TO ELECTRIC SHOCK, FIRE AND MECHANICAL HAZARDS ONLY IN ACCORDANCE WITH UL60601-1.



ATTENTION, CONSULT ACCOMPANYING DOCUMENTS



TYPE B APPLIED PART

# ENVIRONMENTAL CONDITIONS

TRANSPORT/STORAGE TEMPERATURE: -20°C to 40°C

TRANSPORT/STORAGE/OPERATING HUMIDITY: 95% maximum

OPERATING TEMPERATURE: 0°C to 40°C

# SPECIFICATIONS (4010-650)

Maximum Patient Weight	650 lbs (295 kg)
Electrical Supply(Standard)	120V 60HZ 9AMP
Electrical Supply(Optional)	220V 60HZ 5AMP
Power Cord Length	10 FT (3.0m)
Table Weight	450 lbs (204kg)
Paper Roll (Maximum size)	21.0" Long x 3.5" Diameter (53.3 cm x 8.9 cm)
Caster Base Clearance	0.25" from floor

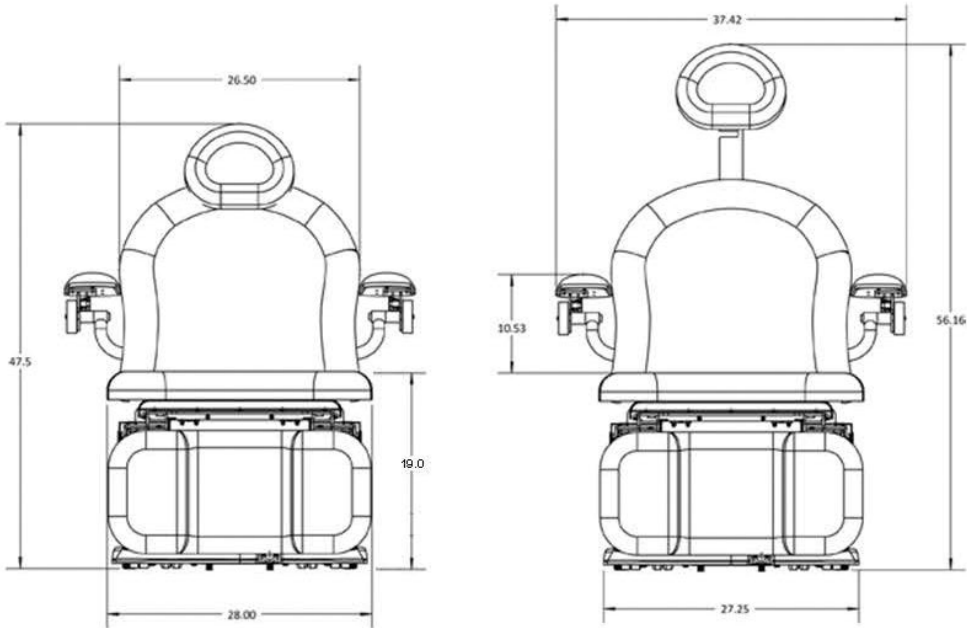

Shown with -047 arm rest accessory

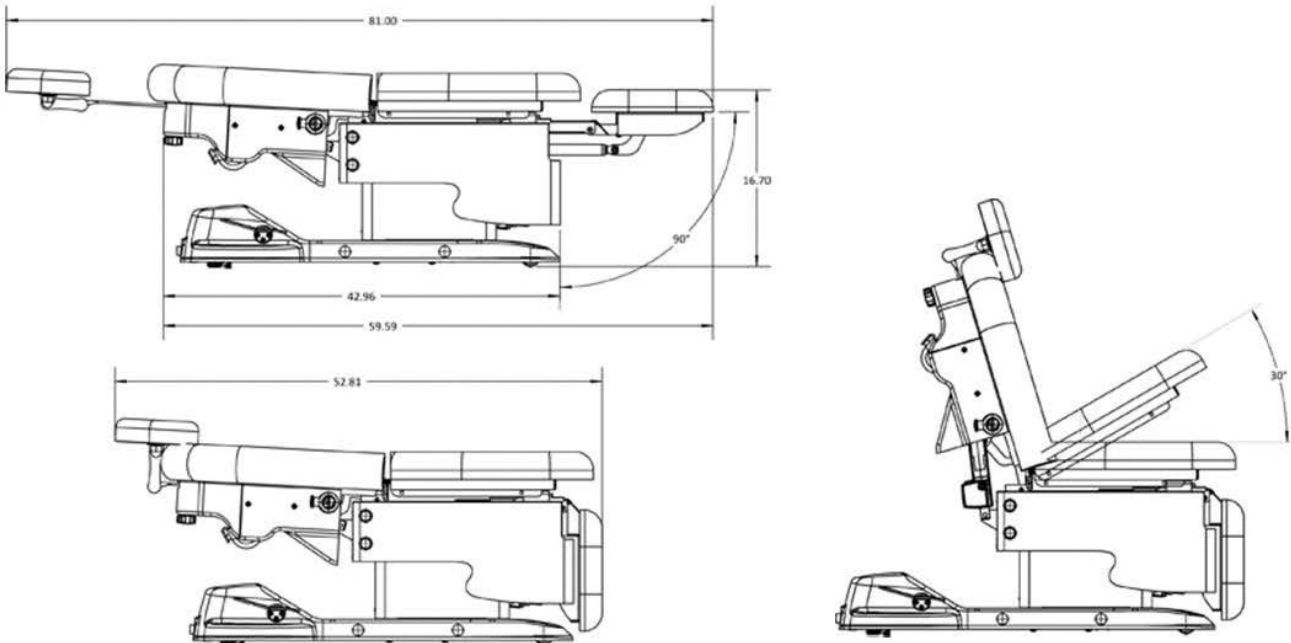

# SPECIFICATIONS (4011-650)

Maximum Patient Weight	650 lbs (295 kg)
Electrical Supply(Standard)	120V 60HZ 9AMP
Electrical Supply(Optional)	220V 60HZ 5AMP
Power Cord Length	10 FT (3.0m)
Table Weight	470 lbs (213kg)
Paper Roll (Maximum size)	21.0" Long x 3.5" Diameter (53.3 cm x 8.9 cm)
Caster Base Clearance	0.25" from floor

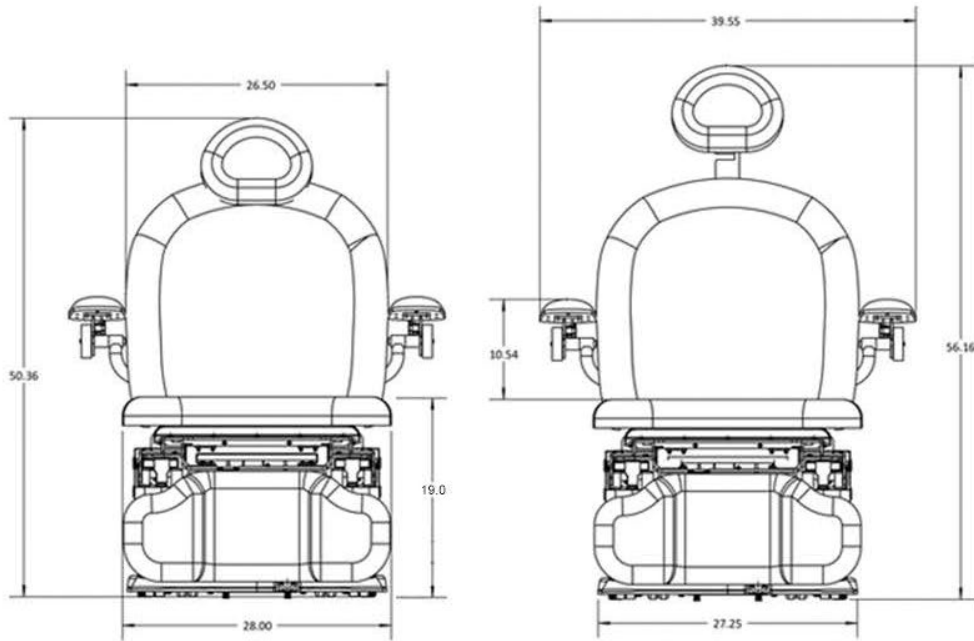

Shown with -044 arm rest accessory

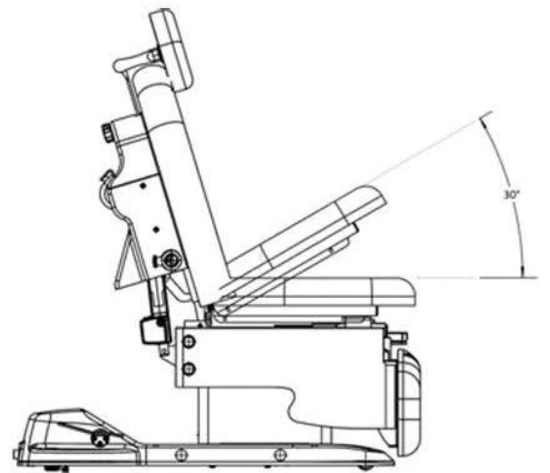
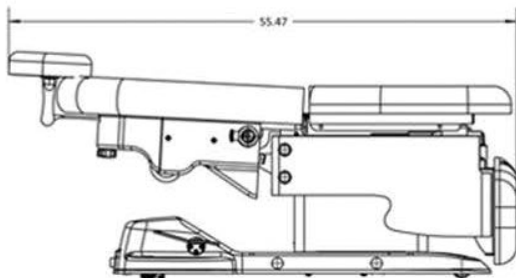
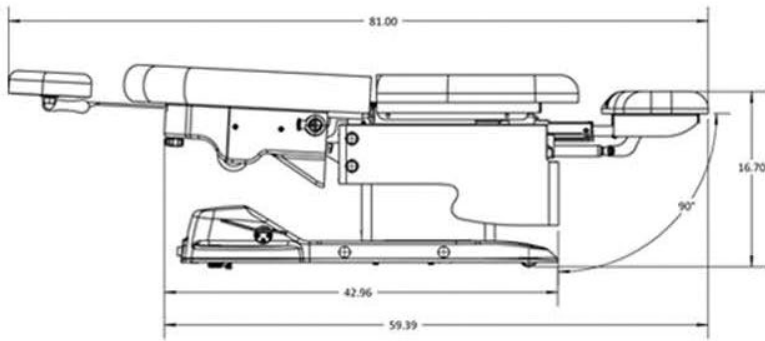

# SPECIFICATIONS (5016-650)

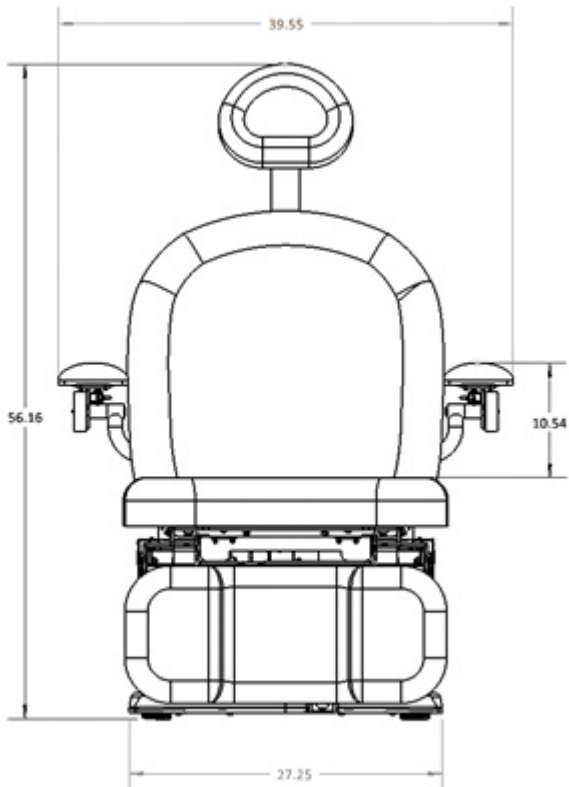
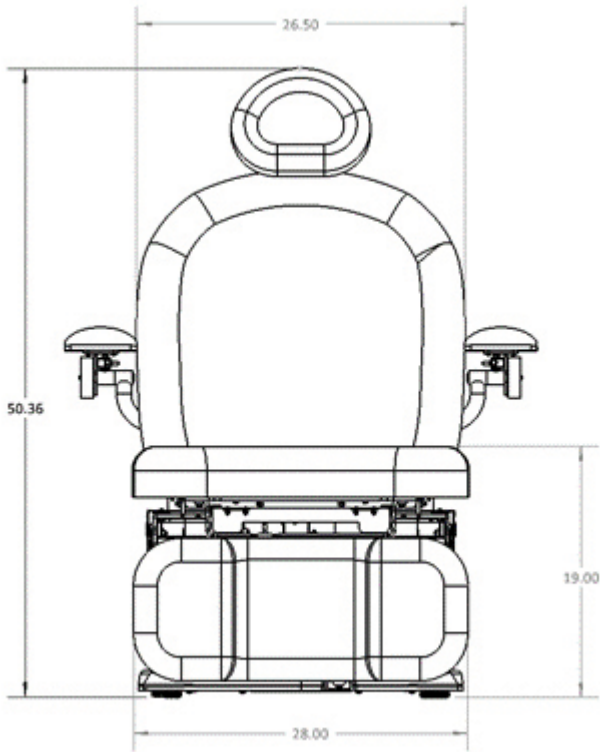

Maximum Patient Weight	650 lbs (295 kg)
Electrical Supply(Standard)	120V 60HZ 9AMP
Electrical Supply(Optional)	220V 60HZ 5AMP
Power Cord Length	10 FT (3.0m)
Table Weight	470 lbs (213kg)
Paper Roll (Maximum size)	21.0" Long x 3.5" Diameter (53.3 cm x 8.9 cm)
Caster Base Clearance	0.25" from floor

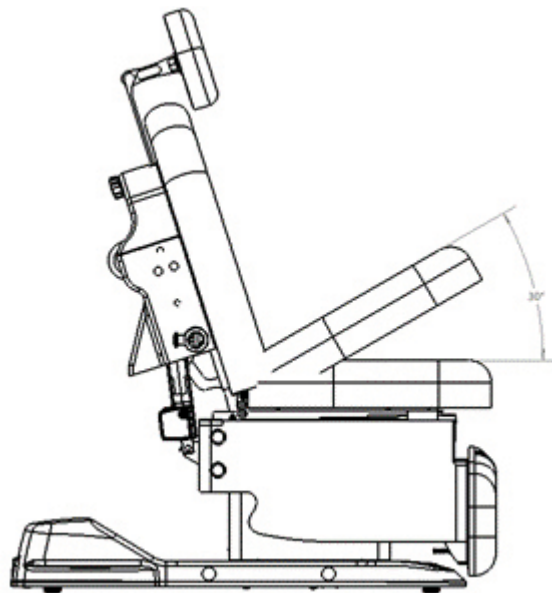
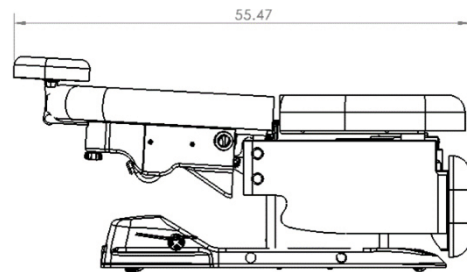
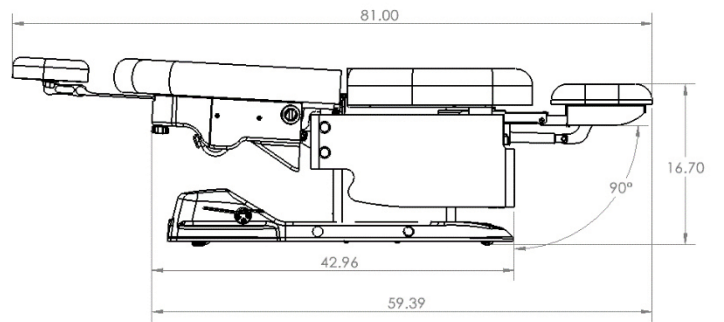

Shown with -044 arm rest accessory

# SAFETY FEATURES

## Patient Safety Table Lockout



Procedure Chair Four-Function Hand Control

This table is equipped with a safety feature that allows the practitioner to deactivate all table functions in order to prevent misuse when staff is not present.

To lock and unlock:

Press & hold STOP button for 2 seconds.

1 beep indicates locked  
2 beeps indicates unlocked

**WARNING:**

FOR MAXIMUM PATIENT SAFETY, LOCK TABLE IMMEDIATELY AFTER EACH USE





# FEATURES AND OPERATION

## Hand & Foot Control – Table Operation



Hand Control

**WARNING:**  
DO NOT USE BACKREST  
AS A SEAT

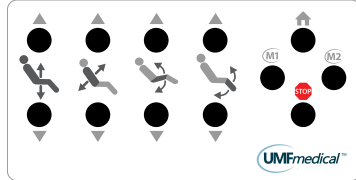

Foot Control



Height  
Adjustment



Backrest  
Adjustment



Legrest  
Adjustment



Pelvic Tilt  
Adjustment



Home

Shown with arm rest accessory

# FEATURES AND OPERATION

## Hand & Foot Control – Memory Programming & Special Functions

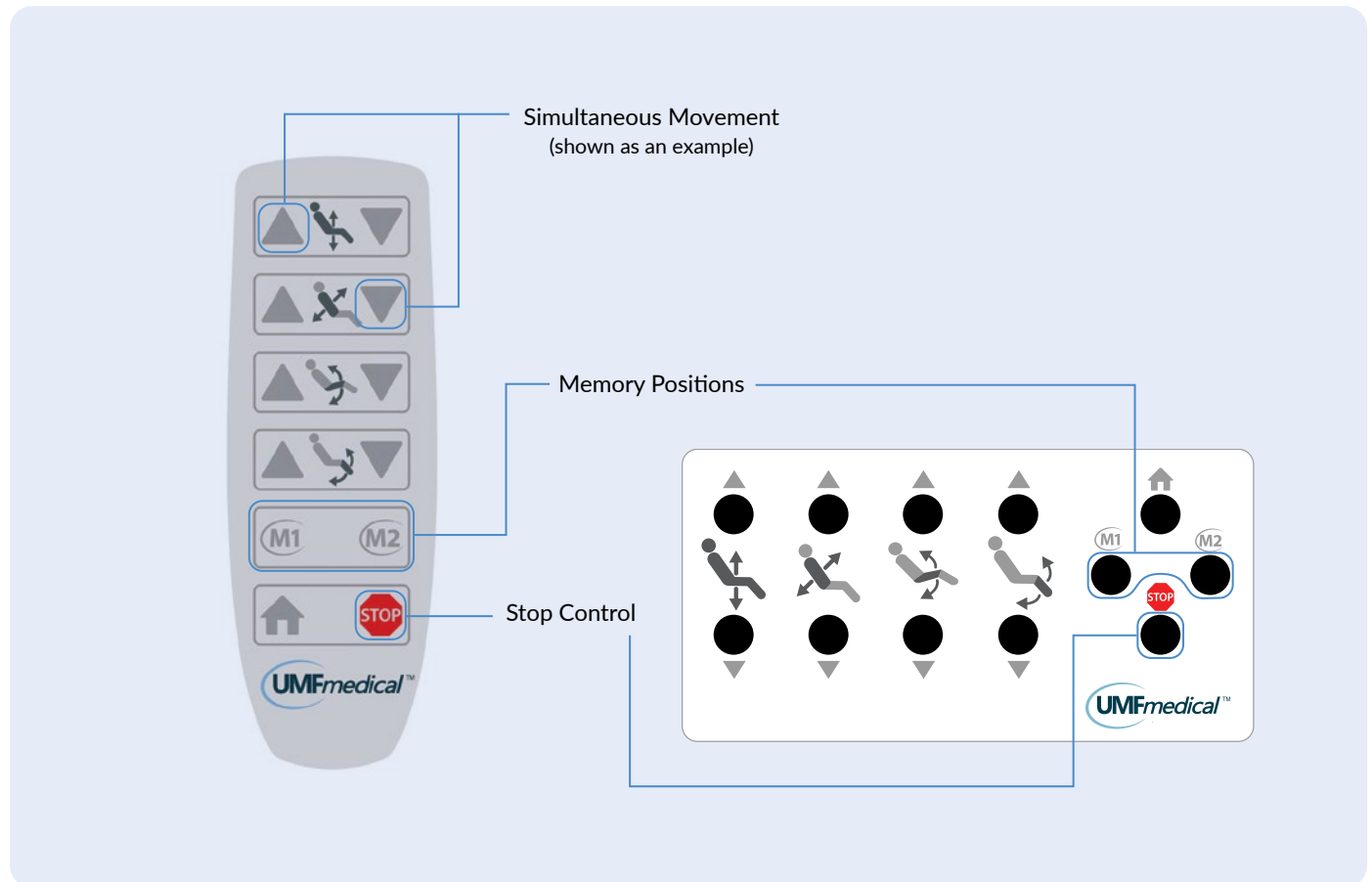

**M1** **M2** – Two programmable positions for storing commonly use table positions.

### To Program:

- 1 Move table to desired position for memory storage.
- 2 Press and hold (approximately 3 seconds) desired memory position button (M1 or M2) in which table position is to be stored. An audible double beep should be heard indicating table position has been programmed.
- 3 To use memory function, press and hold the memory button (M1 or M2) for 1 second. Table will return to programmed position.

Holding the memory button (M1 or M2) for 3 seconds when performing step 3 will cause the memory button to re-program to the current position of the table.

**STOP** – Stops table movement when any impulse movements (HOME, Memory Function M1 or M2) are being used. Pressing any button on the hand or foot control will cancel table movement.

### Simultaneous movement

- › Press any combination of buttons for simultaneous movement of multiple functions



## FEATURES AND OPERATION

### Stirrup Positioning & Adjustment (4011 Model Only)



- 1 Pull the stirrups out and unfold.
- 2 Lift slightly and move left or right to position.

**WARNING:** DO NOT SUPPORT THE PATIENT'S ENTIRE WEIGHT WITH THE STIRRUPS.

**WARNING:** DO NOT RAISE LEGREST WITH THE STIRRUPS OUT

### Drain Pan Access (4011 Model Only)



- 1 Slide out to access drain pan
- 2 Drain pan is removable for easy cleaning.

**WARNING:** DO NOT RAISE LEG REST WITH THE DRAIN PAN OUT

### Paper Roll Replacement



Max Roll Size  
18" x 3.5" (45cm x 9cm)

- 1 Open rotating door to insert paper roll, leave a few inches of paper sticking out.
- 2 Close door firmly.
- 3 Pull paper to desired length.

## FEATURES AND OPERATION

---

### Articulating Head Rest

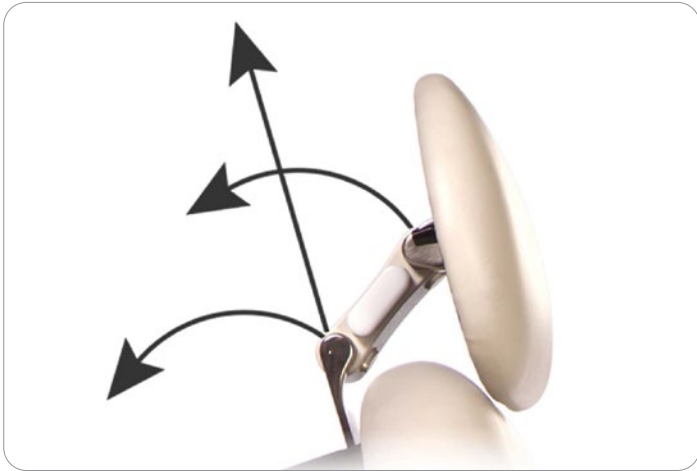

- ① Squeeze adjustment button.
- ② Position the Headrest.
- ③ Release adjustment button to lock headrest in desired place.
- ④ Adjust friction knob so headrest slides smoothly or to lock into position.

# CABLE CONNECTION



**Front**

- 1 Optional port for foot control.

**Back (Left to Right)**

- 1 Foot control port
- 2 False Port
- 3 Hand control port
- 4 Power on LED
- 5 Power cord port

## Cable Locking Feature



- 1 Plug into the hand control port.
- 2 Turn the union nut clockwise until fully threaded.

## COMMON OPTIONS AND ACCESSORIES

### Mobile Caster Base (142) Standard on 300 proGlide Series

Concealed retractable casters can be installed on base to allow for easy table movement for cleaning.



Table in  
LOCKED position



Table in UNLOCKED in  
cleaning position

**WARNING:** TABLE IS NOT TO BE USED FOR PATIENT TRANSPORT. ENSURE WHEELS ARE IN 'PATIENT READY' POSITION PRIOR TO A PATIENT ACCESSING TABLE.

**WARNING:** TABLE IS NOT TO BE USED FOR PATIENT TRANSPORT. CASTERS ARE TO BE USED SOLELY WHEN MOVING TABLE WITHIN THE EXAMINATION ROOM TO FACILITATE CLEANING UNDERNEATH THE TABLE. CASTERS ARE NOT TO BE USED DURING INSTALLATION OR FOR TRANSPORT INSIDE OR OUTSIDE OF FACILITY.

# COMMON OPTIONS AND ACCESSORIES

---

## Multi Positioning Armrests

Shown with arm rest accessory



## COMMON OPTIONS AND ACCESSORIES

### Hospital Grade Receptacle with Child Safe Cover (852)

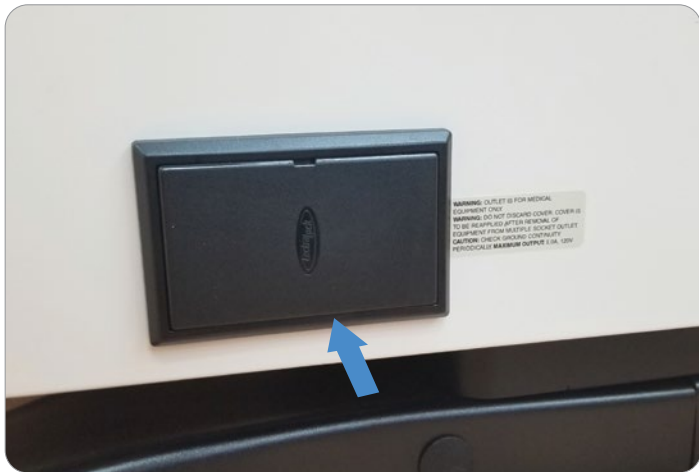

- ① To access receptacles, insert a screwdriver, key, or other tool into slot on receptacle cover to remove child-proof cover.
- ② Replace child-proof cover following use.

**WARNING:** OUTLET IS FOR MEDICAL EQUIPMENT ONLY.  
CAUTION: CHECK GROUND CONTINUITY PERIODICALLY.  
120V MAXIMUM OUTPUT - 5.0A, 120V  
220V MAXIMUM OUTPUT - 2.5A, 220V

**WARNING:** DO NOT DISCARD COVER. COVER IS TO BE REAPPLIED AFTER REMOVAL OF EQUIPMENT FROM MULTIPLE SOCKET OUTLET.

**WARNING:** MULTIPLE SOCKET OUTLET IS TO BE USED FOR MEDICAL EQUIPMENT ONLY (WHERE SAFETY CERTIFICATION HAS BEEN PERFORMED IN ACCORDANCE TO IEC 60601-1 AND/OR IEC 60601-1-1). USE OF EQUIPMENT NOT COMPLYING WITH THE EQUIVALENT SAFETY REQUIREMENT OF THIS EQUIPMENT MAY LEAD TO A REDUCED LEVEL OF SAFETY OF THE RESULTING SYSTEM.

**WARNING:** GROUND RELIABILITY CAN ONLY BE ACHIEVED WHEN POWER SUPPLY IS CONNECTED TO AN EQUIVALENT RECEPTACLE MARKED "HOSPITAL ONLY" OR "HOSPITAL GRADE".

**Service Note:** If the maximum load of the receptacle is exceeded, two circuit breakers will interrupt power. To reset, toggle the far two circuit breakers located behind the receptacle outlet box in the back of the drawer panel.

## Exam Table Upholstery with PreFixx® Protective Finish Helping to enhance infection prevention initiatives

In laboratory testing, upholstery protected with PreFixx® finish was treated with the following disinfectants with little to no discoloration or damage to the upholstery. This testing may not reflect actual results in the field.\*

### Recommended Disinfectants\*\*

- › Clorox® Broad Spectrum Quaternary Disinfectant Cleaner
- › Clorox® Healthcare Bleach Germicidal Cleaner
- › Clorox® Healthcare Bleach Germicidal Wipes
- › Clorox® Healthcare EZ-KILL® Wipes
- › Clorox® Healthcare VersaSure® Cleaner Disinfection Wipes
- › Clorox® Hydrogen Peroxide Cleaner Disinfectant Spray
- › Clorox® Hydrogen Peroxide Cleaner Disinfectant Wipes
- › Agar™ Powerquat
- › Asepticare™
- › Asepticare™ TB-II
- › AVISTAT-D™ Ready To Use Spray Disinfectant Cleaner
- › Biotrol BirexSE®
- › Bleach 1:5 (20% bleach)
- › Bleach 1:9 (10% bleach)
- › Bleach-Rite® Disinfecting Spray
- › CaviCide™
- › CaviCide1™

- › CaviCide™ AF
- › Diversey™ Accel® INTERvention® Wipes
- › Diversey™ Avert® Sporidical Disinfectant Cleaner
- › ERC Performance Wipes
- › McKesson Disposable Germicidal Surface Wipes
- › McKesson Pro-Tech RTU Disinfectant Cleaner
- › OPTIM® 1 Wipes
- › OPTIM® 33TB
- › Oxivir® 1 RTU
- › Oxivir® Five 16
- › Oxivir® TB
- › OxyCide™ Daily Disinfectant Cleaner
- › PDI Sani-Cloth® AF3 Germicidal Disposable Wipes
- › PDI Sani-Cloth® HB
- › PDI Sani-Cloth® Plus
- › PDI Sani-Cloth® Prime Germicidal Disposable Wipe
- › PDI Super Sani-Cloth®
- › PDI Super Sani-Cloth® Bleach Germicidal Disposable Wipes
- › Precise QTB Spray
- › PROCHEM® Oxy Plus
- › Purell® Healthcare Surface Disinfectant
- › Purell® Multi-Surface Disinfectant
- › Sani Professional® Cleaning + Degreasing Multi-Surface Wipes
- › Sani Professional® Multi-Surface Cleaning Wipes
- › Sani Professional® No-Rinse Sanitizing Multi-Surface Wipes
- › SaniZide® Plus
- › STERI-7 XTRA CONCENTRATE (recommended dilution ratio 1:10)
- › STERI-7 XTRA WIPES
- › Vert-2-Go ED
- › Virox AHP 5
- › Virox PREempt™ RTU
- › Virex® II 256
- › Virex® Plus One-Step Disinfectant Cleaner & Deodorant
- › Wayne® Concept 256N
- › Wex-Cide 128



### Care & Cleaning

Use one of the following cleaners with a soft cloth or damp sponge. Rinse area with fresh water then dry with a clean, lint-free cloth.

#### Primary Recommended Cleaner

- › Formula 409 All-Purpose spray cleaner
- › Fantastik spray cleaner

#### Secondary Recommended Cleaners

- › Lysol Clean and Fresh Multi-Surface Cleaner (Reckitt Benckiser)
- › Lestoil Heavy Duty Cleaner (Clorox)
- › Mr. Clean / Flash Clean and Shine (Procter and Gamble)
- › Eco Touch All Purpose Premium Care

For more difficult stains, contact UMF Medical Customer Service.

\*All disinfectants and cleaning agents contain chemicals that degrade coated fabric upholstery to some extent. To promote a long product life, it is recommended that the PreFixx cleaning and maintenance protocol be employed regularly.

\*\*Inclusion in this document does not imply "fit for use." Customers should first determine if products are appropriate for use on their surfaces.



# EQUIPMENT CARE

---

## Care of upholstery

The upholstery material used on the top, leg rest, and headrest is resistant to most medical stains.

### For light cleaning:

- 1 A solution of 10% liquid soap and clean water applied with a soft damp cloth will remove disinfection cleaner build-up.
- 2 If necessary, a solution of liquid cleanser and water can be applied with a soft bristle brush. Wipe away residue with a water-dampened cloth.

### For disinfection:

- 1 Dampen a soft white cloth with a solution of standard bleach (sodium hypochlorite) or other chlorine-based cleaner\*\*\* and water; 10% bleach, 90% water.
- 2 Rub gently.
- 3 If necessary, allow the 1:10 diluted bleach (sodium hypochlorite) solution to puddle on the affected area or apply with a clean, soaked cloth for approximately 30 minutes. Rinse with a water-dampened cloth to remove any remaining bleach concentration.
- 4 Rinse with a water-dampened cloth to remove cleaner solution and allow thorough drying of material.

\*\*\*See current CDC Guideline for Disinfection & Sterilization in Healthcare Facilities for bleach alternative cleaners.

Note: Immediately remove any fluid spilled on upholstery surface.

Antimicrobial: UMF Medical Upholstery provides outstanding protection in difficult medical and healthcare environments and contains an agent effective against bacterial and fungal microorganisms.

## Care of painted surfaces

A chemical acid-resistant paint is used, but extreme care must be taken not to use ammonia-based cleaners or discoloration of paint may occur. A damp cloth or mild liquid soap solution should be sufficient.

## Care of bright metal surfaces

All non-painted surfaces, chrome plated, or stainless steel should be wiped weekly with a clean damp cloth then buffed to a lustrous shine with a soft dry cloth.

## Care of base

The protective base is easily washable with mild liquid soap and water. A soft bristle brush may be used on scuffed or stained areas.

**CAUTION:** WHEN THE USE OF STRONG CLEANING SOLUTIONS IS NECESSARY, TEST AN INCONSPICUOUS AREA TO ASSURE THAT DAMAGE TO UPHOLSTERY OR PAINTED SURFACES WILL NOT OCCUR.

# QUESTIONS, COMMENTS OR SERVICE REQUESTS

---

## Contact:

UMF Medical Customer Service  
1316 Eisenhower Blvd  
Johnstown, PA 15904

Toll Free: 1(800) 638-5322  
Email: customerservice@umfmedical.com  
Fax: 1(814) 266-1870

\* For service requests, please have model & serial number available.

# WARRANTY INFORMATION

UMF Medical warrants to the original purchaser a warranty for products to be free from functional defects in material and workmanship under normal interior use and service. UMF Medical's obligation under this warranty is limited to the repair or replacement, at UMF Medical's option, of the parts or the products the defects of which are reported to UMF Medical within the applicable warranty period and which upon examination by UMF Medical prove to be defective. Warranty subject to the terms and conditions listed below.

## Length of warranty, measured by Purchase Date (Invoice Date), for all warranted products and components:

- Five years:* Signature Series Examination Tables (52xx model numbers and Treatment and Orthopedic Tables (55xx model numbers). Ultra-Comfort adjustable backrest cylinder not included.
- Three years:* Power Exam and Procedure Tables and all other UMF Medical products excluding the products listed in Five Year and One Year categories of this document.
- One year:* Waste Receptacles, Bassinet Baskets, Bassinet Mattresses and ultra-comfort adjustable backrest cylinder.

## Obtaining Warranty Service

Warranty service must be obtained by contacting either the Authorized Distributor through whom the product was purchased or UMF Medical Customer Service Department via phone at 814-266-8726, or via email at customerservice@umfmedical.com.

This warranty covers the cost associated with the repair parts only and does not cover any other charges, including but not limited to service calls, labor, transportation, shipping, etc. It is the retail customer's obligation to arrange delivery of a product to UMF Medical or one of its authorized distributors for warranty service, which delivery shall be at the retail purchaser's expense. It is also the retail purchaser's obligation to comply with the warranty service instruction provided by UMF Medical or its authorized distributor. The retail purchaser must provide UMF Medical with completed warranty registration information within thirty days after purchase in order to obtain the benefits of this warranty.

## Limited warranty general exceptions and exclusions

This warranty does not cover and UMF Medical shall not be liable for the following:

- › Parts and products of a consumable nature;
- › Defects, damage or other conditions caused, in whole or in part, by mishandling, misuse, abuse, negligence, alteration,

accident, freight damage, tampering or failure to seek and obtain repair or replacement in a timely manner;

- › Products which are not installed, used, and properly cleaned and maintained as required in the UMF Medical installation and/or Owner's Manual for the applicable product;
- › Replacement parts, alterations or installation of any accessories or parts not manufactured or recommended by UMF Medical;
- › Cosmetic and non-functional defects not noted at time of delivery.
- › Charges for repairs, replacement parts, adjustments, installation or other work performed upon or in connection with products which are not expressly authorized in writing in advance by UMF Medical.
- › Damages resulting from inadequate power supply (including incorrect voltage, voltage spikes or other irregularities) or use or storage in corrosive atmospheres.

To the extent any or all of the following exclusions or provisions of this warranty are prohibited by any federal, state, or municipal law which cannot be preempted, those exclusions or provisions shall not be applicable.

## Exclusive Remedy: Consequential Damages Disclaimer

UMF Medical's only obligation under this warranty is the repair or replacement of defective parts. UMF Medical shall not be liable for and hereby disclaims any direct, special, indirect, incidental, exemplary or consequential damages or delays, including but not limited to, damages for loss of profits or income, loss of use, downtime, employee or independent contractor wages, payments and benefits, commercial loss or other incidental charges.

## No Authorization

No person or firm is authorized to create or approve for UMF Medical any other obligation or liability in connection with the products.

## Warranty Disclaimer

THIS WARRANTY IS UMF MEDICAL'S ONLY WARRANTY AND IS IN LIEU OF ALL OTHER WARRANTIES, EXPRESS OR IMPLIED. UMF MEDICAL MAKES NO IMPLIED WARRANTIES OF ANY KIND INCLUDING ANY IMPLIED WARRANTIES OR MERCHANTABILITY OR FITNESS FOR A PARTICULAR PURPOSE. THIS WARRANTY IS LIMITED TO THE REPAIR OR REPLACEMENT OF DEFECTIVE PARTS.

No action may be brought against UMF Medical for breach of this limited warranty, an implied warranty, if any, or for any other claim arising out of or relating to the products following expiration of the limited warranty period.

UMF Medical reserves the right to make changes in the design or material of its products without incurring any obligation to incorporate such changes in any product previously manufactured.

# SETUP INSTRUCTIONS

---

## Models 4010/4011/5016-650-100 (Power4010, Power4011, Power5016)

### To set up your New Power Table:

**PLEASE FOLLOW THESE STEPS COMPLETELY to ensure that your table functions properly PLEASE DO NOT PLUG TABLE IN UNTIL PRECEDING STEPS ARE COMPLETED.**

1. Locate the hand control port at the rear of the table base.
2. Locate green dot on the port at the rear of the table base.
3. Locate green dot on the plug end of the hand control.
4. Align green dot on plug with green dot on port.
5. Plug in hand control completely, ensuring that yellow 'O' ring is completely inserted into the port until the yellow color completely disappears.  
NOTE: IF YELLOW O-RING IS NOT COMPLETELY INSERTED INTO THE PORT, THE TABLE WILL NOT FUNCTION. THE TABLE WILL BEEP AND REQUIRE A CONTROL BOX RESET. THIS IS A SAFETY FEATURE.
6. Slide the round crew lock forward over the port plug and turn clockwise to tighten. Ensure completely tight.
7. Plug power cord into the port in the exam table.
8. Plug power cord into the wall outlet.

## Models 4010/4011/5016-650-200 & 300 (Power4010p, Power4011p, Power5016p, ProGlide4010, ProGlide4011, ProGlide5016)

### To set up your New Power Table:

**PLEASE FOLLOW THESE STEPS COMPLETELY to ensure that your table functions properly PLEASE DO NOT PLUG TABLE IN UNTIL PRECEDING STEPS ARE COMPLETED.**

1. The table has two (2) ports for the foot control, one (1) located at the front and one (1) located at the rear. Locate the ports and choose which port to plug in your foot control.
2. The table has one (1) port for the hand control located in the rear of the table base.
3. Start with installing the hand control.
4. Locate the hand control port at the rear of the table base.
5. Locate green dot on the port at the rear of the table base.
6. Locate green dot on the plug end of the hand control.
7. Align green dot on plug with green dot on port.
8. Plug in hand control completely, ensuring that yellow 'O' ring is completely inserted into the port until the yellow color completely disappears.  
NOTE: IF YELLOW O-RING IS NOT COMPLETELY INSERTED INTO THE PORT, THE TABLE WILL NOT FUNCTION. THE TABLE WILL BEEP AND REQUIRE A CONTROL BOX RESET. THIS IS A SAFETY FEATURE.
9. Slide the round crew lock forward over the port plug and turn clockwise to tighten. Ensure completely tight.
10. Choose the port in the front or rear of the table for your foot control.
11. Locate green dot on the port.
12. Locate green dot on the plug end of the foot control.
13. Align green dot on plug with green dot on port.
14. Plug in foot control completely, ensuring that yellow 'O' ring is completely inserted into the port until the yellow color completely disappears.  
NOTE: IF YELLOW O-RING IS NOT COMPLETELY INSERTED INTO THE PORT, THE TABLE WILL NOT FUNCTION. THE TABLE WILL BEEP AND REQUIRE A CONTROL BOX RESET. THIS IS A SAFETY FEATURE.
15. Slide the round crew lock forward over the port plug and turn clockwise to tighten. Ensure completely tight.
16. Plug power cord into the port in the exam table
17. Plug power cord into the wall outlet