

**UMF Medical 4040/4070
Power Exam Tables Unique
and Salient Characteristics**

Table of Contents

I. Product Description & Intended Use.....	3
II. Unique Characteristics.....	3
a. Equipment Life Cycle Management Program	3
b. Mechanical OneTouch WheelBase® System (4040-650-300 & 4070-650-300 only)	4
c. Removable upholstery with PreFixx® Protective Finish.....	5
d. Plug-n-play componentry	9
e. Footprint.....	9
f. Storage drawers.....	9
g. Leg rest with privacy side pulls.....	12
h. Hand control with OneTouch Patient Positioning® System	12
i. Warranty.....	18
III. Salient Characteristics.....	20
a. High-low function	20
b. Easy-clean powder coated base	20
c. Power back function (4040 models only)	20
d. Manual back function (4070 Series only)	20
e. Low ADA table height	20
f. Foot control	21
g. Weight capacity	21
h. Stirrups	21
i. Drawer warmer	22
j. Stainless steel drip pan.....	22
k. Pelvic tilt	23
l. Tamper-Resistant electrical receptacle.....	23
m. Paper roll holder	23
IV. Environmental Conditions	24
V. Specifications	25
VI. Patient Safety Table Lockout.....	27
VII. Equipment Care.....	28
VIII. Care and Cleaning.....	29

I. Product Description & Intended Use

The 4040/4070 Series Power Exam Tables are versatile medical devices designed for healthcare professionals in clinic, hospital, and healthcare facility settings. These hi-lo, ADA-accessible power exam tables help to facilitate patient examinations, treatments and/or procedures in a seated or lying position.

Equipped with motorized functions, the tables enable precise adjustments of the height, backrest, and leg sections. This allows healthcare professionals to optimize patient comfort, accessibility, and proper positioning during examinations, diagnostics, and minor medical procedures across various medical disciplines.

It is important to note that these power exam tables are intended to be used as an aid during patient examinations and do not possess diagnostic or therapeutic capabilities on their own. They offer enhanced versatility and convenience for healthcare professionals, improving the examination process.

Users of the power exam tables should receive proper training on their operation and adhere to relevant safety guidelines. They should be used in suitable environments and maintained according to the manufacturer's instructions. For specific information on features, limitations, and maintenance requirements, please consult the manufacturer's user manual and guidelines. NOT intended for patient transport.

II. Unique Characteristics

a. Unique Characteristics Quick Reference

Feature	Advantage	Unique Benefit
Equipment Life Cycle Management Program	One-time price of product acquisition. FOB destination dock-to-dock shipping. All-inclusive support and maintenance.	Enable VA to gain insights into total cost of ownership, identify opportunities for savings and make informed decisions. Comprehensive support over a 10-year
Mechanical One-Touch WheelBase® System	Ability to move table for cleaning, to reposition for patients, change rooms or to storage area.	No electricity required. No cord length limitation. Can engage or disengage mobile base without external electrical – mechanical operation. Can move table even during power outages.
Removable Upholstery	Turning slide latches on back of table top, the entire top can be removed for cleaning or replacement. No tools are required.	When required to clean or exchange upholstery, limited time and effort is required to remove top, and access for cleaning is greatly increased.
PreFixx™ Protective Finish	Non-porous material with a broad list of cleaning disinfectants to ease the cleaning process.	Easier to clean and reduce bio-burden on the top to reduce cross-contamination between Veterans.
Plug-n-Play Components	Incorporation of components that fit multiple versions of UMF Medical tables reduces spare part options and inventory. Easily replaced by unplugging and plugging in replacement.	Decreased downtime when an issue does occur and eliminates the need for specialized trained service technicians, thereby reducing costs. Plug-n-play on an exam table allows in-house technicians to focus on life-saving equipment/devices.

Footprint	Compared to other tables, the UMF Medical tables have a smaller footprint and thereby are compatible with different size exam rooms.	Better utilization of space in an exam room area and flexibility of use of the room.
Storage Drawers	Two storage drawers, including a reversible side drawer.	80% more storage than comparable tables. Flexibility to place reversible drawer on either side of the table as needed.
Leg Rest with Privacy Side Pulls	Privacy side pulls on front corners of the legrest for easy access.	No need to reach between patient's legs to pull out the legrest.
OneTouch Patient Positioning® System Hand Control	Two programmable memory positions and return-to-home feature.	Store commonly used table positions and position with one touch.
Warranty	3-year warranty.	Best-in-industry warranty.
10-year life cycle	10-year life cycle.	Support and maintenance for 10 years.

b. Equipment Life Cycle Management Program

The Power Exam Table Equipment Life Cycle Management Program is a holistic approach to managing power exam table acquisition. Enabling the VA to gain insights into total cost of ownership, identify opportunities for savings and make informed decisions, this bundled solution includes:

1. One-time price of product acquisition - Pay a single price covering the product, delivery, preventative maintenance, and all parts and repairs for a 10-year life cycle.
2. FOB destination dock-to-dock shipping -- Receive hassle-free delivery directly to your destination, ensuring a seamless and efficient process for receiving your exam tables.
3. All-inclusive support and maintenance -- Enjoy peace of mind with coverage on all aspects of maintenance, including parts, labor, and expert assistance, ensuring your exam table functions at its peak for the entire duration.

c. Mechanical OneTouch WheelBase® System (4040-650-300 & 4070-650-300 only)

The OneTouch WheelBase® System features integrated central-locking casters with an intuitive mechanical foot pedal that enables staff to move the exam table quickly and easily for cleaning and disinfecting, and then lock it solidly into place for exams. Electricity is **not** required to activate the wheelbase. It is completely mechanical so there is no power cord limitation, and it can even be used during power outages.

- Quickly gain access to clean and disinfect under and around the exam table, helping to reduce healthcare-associated infections.

- Conveniently flex room space - no more heavy lifting is needed to move equipment.
- Comfortably accommodate more patients – equipment is easy to move if a patient needs more room to access the exam table.



WARNING: TABLE IS NOT TO BE USED FOR PATIENT TRANSPORT. ENSURE WHEELS ARE IN 'PATIENT READY' POSITION PRIOR TO A PATIENT ACCESSING TABLE.

WARNING: TABLE IS NOT TO BE USED FOR PATIENT TRANSPORT. CASTERS ARE TO BE USED SOLELY WHEN MOVING TABLE WITHIN THE EXAMINATION ROOM TO FACILITATE CLEANING UNDERNEATH THE TABLE. CASTERS ARE NOT TO BE USED DURING INSTALLATION OR FOR TRANSPORT INSIDE OR OUTSIDE OF FACILITY.

CAUTION: LOW GROUND CLEARANCE WHEN TABLE IS ENGAGED IN CLEANING POSITION. AVOID ROLLING TABLE OVER OBJECTS GREATER THAN .25" HIGH OR DAMAGE MAY OCCUR.

d. Removable upholstery with PreFixx® Protective Finish

UMF Medical's seamless, removable upholstery with PreFixx Protective Finish is designed for easy cleaning and decontamination. This helps to reduce the risk of infection and increase the useful life of the exam table while maintaining the aesthetics of the exam room across the 16 available color options.

The upholstery with PreFixx Protective Finish is:

- Non-porous and engineered for repeated cleaning and disinfection
- Compatible with a broad range of common healthcare cleaners and disinfectants (See manufacturer's approved cleaners and disinfectants list.)
- Resistant to dirt, staining, discoloration, damage, scuffs, abrasions and bacteria growth
- Eco-preferred and does not contain phthalates, fire retardants, or antimicrobial additives

This padded upholstered top is easy to install and remove as needed.

Upholstery Installation

Step 1

Carefully lay upholstered top on table, aligning black slide latches on underside of upholstery with cutouts in support pan.



Step 2

Slide latches may not be perfectly aligned when upholstery is resting on the support pan. Proceed to next step.



Step 3

If latches are not properly aligned, slightly raise foot section and maneuver upholstery lightly until all latches align properly.



Step 4

Raise the back section of the upholstery and support pan (4070-650:) by squeezing the manual release lever and gently lifting upward. (4040-650:) by using hand or foot control.



Step 5

Using your index finger, slide all four black slides latches toward the center of the support pan until fully engaged. Lower the back section.



Step 6

Raise the foot section of the upholstery and support pan and repeat step five for the remaining four black slide latches. Lower the foot section.



Upholstery Removal

Step 1

Grasp slide latch with thumb and forefinger.



Step 3

While pulling toward you (away from the pan), slide the latch to the unlocked position.

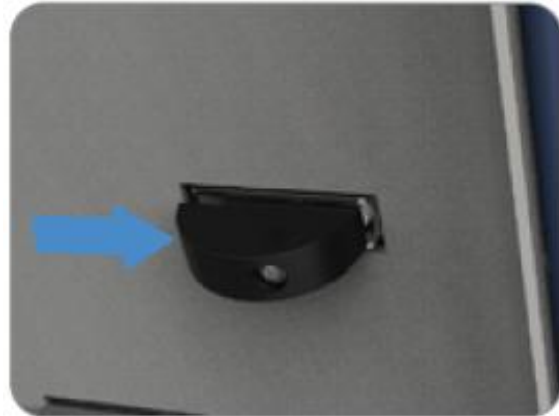

Step 2

Pull the slide latch toward you (away from the metal pan).



Step 4

Allow the latch to return to its normal position. Repeat for all latches.



e. Plug-n-play componentry

The 4040/4070 Series Power Exam Tables were designed with simple, plug-n-play componentry and to be easily accessible for repairs and reassembly.

This intentional design was aimed at reducing parts and labor expenses associated with break/fix scenarios. The same simple plug-n-play componentry can be used on multiple exam table and procedure chair products and minimizes the need for extensive repairs and replacement, contributing to cost-effectiveness. Users will also appreciate minimal downtime, helping to ensure the power exam tables remain operational with reduced disruptions to facility workflow.

f. Footprint

The 4040/4070 Series Power Exam Tables have one of the smallest footprints of comparable exam tables on the market. This smaller footprint helps to optimize space and enhance efficiency, especially in smaller exam and treatment rooms. This design contributes to better workflow and aids in the overall organization of the clinic, improving the patient experience during examinations.

g. Storage drawers

The storage drawers on the 4040/4070 Series Power Exam Tables provide organized space for medical equipment, instruments, and supplies, ensuring quick access during examinations. They provide nearly 80% more storage space than other comparable exam tables on the market with front and side storage drawers (-200 and -300 models only). The reversible side drawer allows the flexibility to place the drawer on the side of the table that works best for the exam room workflow and efficiency.

With drawers integrated into the exam table, healthcare professionals can avoid leaving the examination room to search for supplies, promoting a seamless workflow, saving time, and enhancing efficient patient care. This contributes to a smoother, more patient-centric examination experience.

Storage Drawers



Side Drawer
24.5" x 12.5" x 3.5"
(62cm x 32cm x 9cm)



Front Drawer
19.0" x 12.0" x 3.5"
(48cm x 30cm x 9cm)

Reversing Side Drawers

Step 1

Carefully lay upholstered top on table, aligning black slide latches on underside of upholstery with cutouts in support pan.



Step 3

If latches are not properly aligned, slightly raise foot section and maneuver upholstery lightly until all latches align properly.



Step 2

Slide latches may not be perfectly aligned when upholstery is resting on the support pan. Proceed to next step.



Step 4

Raise the back section of the upholstery and support pan (4070-650:) by squeezing the manual release lever and gently lifting upward. (4040-650:) by using hand or foot control.



Step 5

Using your index finger, slide all four black slides latches toward the center of the support pan until fully engaged. Lower the back section.



h. Leg rest with privacy side pulls

Each model in the 4040/4070 Series comes standard with a pull-out leg section, equipped with privacy side pulls. The privacy side pulls, located on the front corners of the leg rest, make it convenient for clinical staff to access the leg rest from the side of the table without having to reach between the patient's legs to pull it out.

i. Hand control with OneTouch Patient Positioning® System

The 4040/4070 Series Power Exam Table (-200 and -300 models only) includes a hand control with OneTouch Patient Positioning® System – two programmable memory positions and a return-to-home feature.

Staff can program the memory buttons to store commonly used table positions, and with one touch, the exam table can move to those pre-programmed positions.

The hand control also includes a return-to-home button that, when pressed, places the exam table back into the upright seated position. The Stop button immediately stops table movement when any impulse movements (Home or Memory buttons) are being used.

In addition, the power hi-lo buttons allow the table to move from low, ADA height to fully extended height. The power backrest up and down buttons (4040 models only) allow the table to be positioned anywhere from flat to upright seated positions.

Hand Control

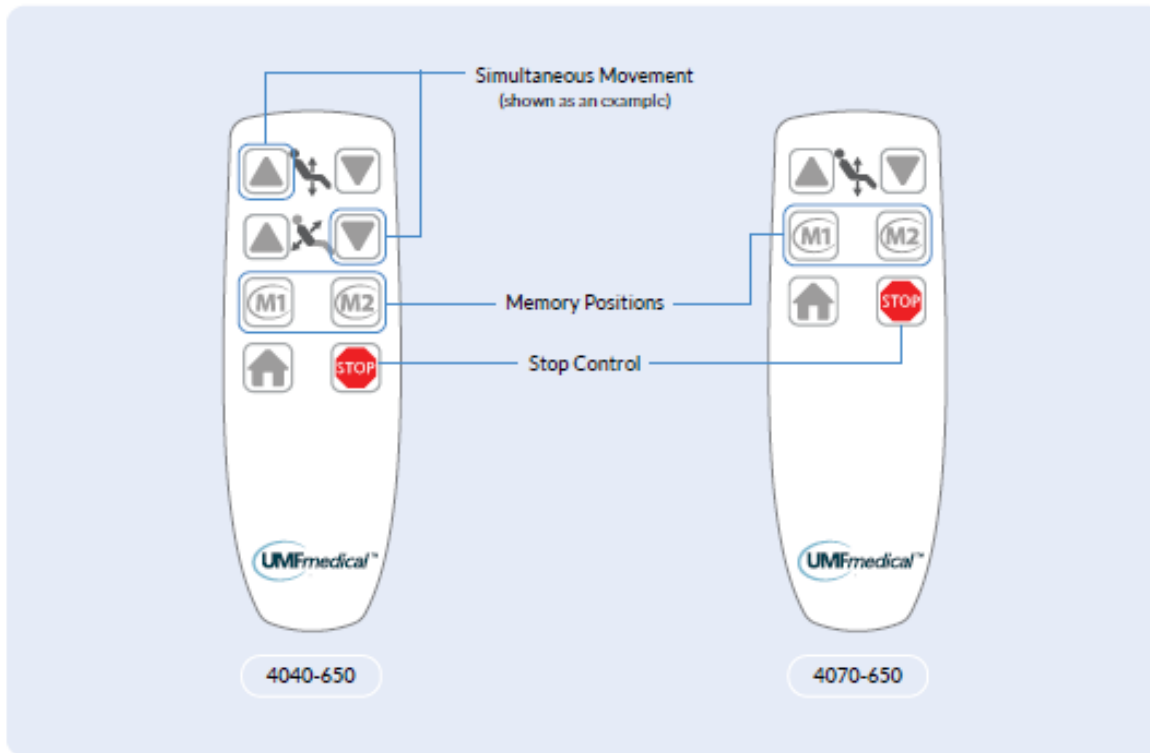

  – Two programmable positions for storing commonly use table positions.

To Program:

- 1 Move table to desired position for memory storage.
- 2 Press and hold (approximately 3 seconds) desired memory position button (M1 or M2) in which table position is to be stored. An audible double beep should be heard indicating table position has been programmed.
- 3 To use memory function, press and hold the memory button (M1 or M2) for 1 second. Table will return to programmed position.

Holding the memory button (M1 or M2) for 3 seconds when performing step 3 will cause the memory button to re-program to the current position of the table.

 – Stops table movement when any impulse movements (HOME, Memory Function M1 or M2) are being used. Pressing any button on the hand or foot control will cancel table movement.

Simultaneous movement

- › Press any combination of buttons for simultaneous movement of multiple functions|

Hand Control for 4040-650

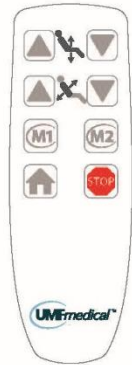

Hand Control



Height Adjustment



Home



Backrest Adjustment

WARNING: DO NOT USE BACKREST AS A SEAT

Hand Control for 4070-650



Hand Control



Height Adjustment



Home

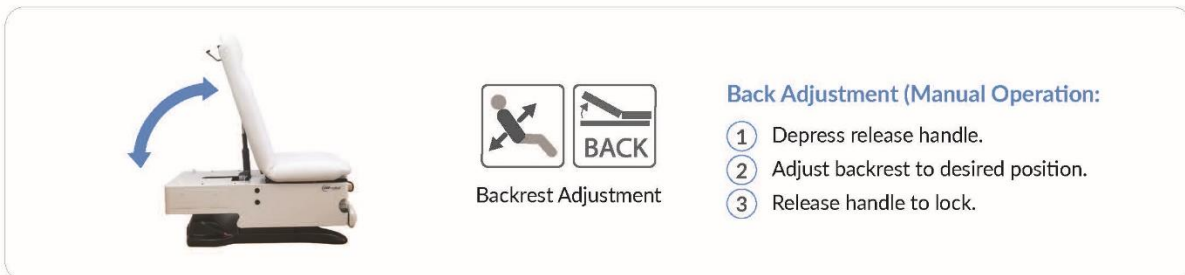

Backrest Adjustment

WARNING: DO NOT USE BACKREST AS A SEAT

Foot Control for 4040-650

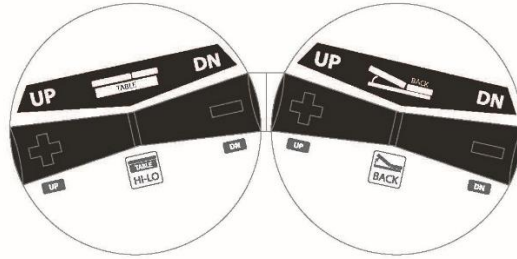

Foot Control



WARNING: DO NOT USE BACKREST AS A SEAT

Foot Control for 4070-650

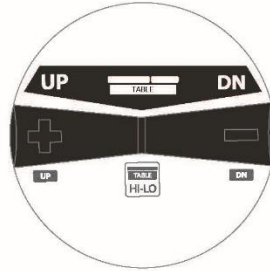

Foot Control



Height Adjustment



Home



Backrest Adjustment

Back Adjustment (Manual Operation:

- 1 Depress release handle.
- 2 Adjust backrest to desired position.
- 3 Release handle to lock.

WARNING: DO NOT USE BACKREST AS A SEAT

j. Warranty

UMF Medical warrants to the original purchaser a warranty for products to be free from functional defects in material and workmanship under normal interior use and service. UMF Medical's obligation under this warranty is limited to the repair or replacement, at UMF Medical's option, of the parts or the products the defects of which are reported to UMF Medical within the applicable warranty period and which upon examination by UMF Medical prove to be defective. Warranty subject to the terms and conditions listed below.

Length of warranty, measured by Purchase Date (Invoice Date), for all warranted products and components:

THREE YEARS

Power Exam and Procedure Tables and all other UMF Medical products excluding the products listed in Five Year and One Year categories of this document.

Obtaining Warranty Service

Warranty service must be obtained by contacting either the Authorized Distributor through whom the product was purchased or UMF Medical Customer Service Department via phone at 814-266-8726, or via email at customerservice@umfmedical.com.

This warranty covers the cost associated with the repair parts only and does not cover any other charges, including but not limited to service calls, labor, transportation, shipping, etc. It is the retail customer's obligation to arrange delivery of a product to UMF Medical or one of its authorized distributors for warranty service, which delivery shall be at the retail purchaser's expense. It is also the retail purchaser's obligation to comply with the warranty service instruction provided by UMF Medical or its authorized distributor. The retail purchaser must provide UMF Medical with completed warranty registration information within thirty days after purchase in order to obtain the benefits of this warranty.

Limited warranty general exceptions and exclusions

This warranty does not cover and UMF Medical shall not be liable for the following:

- Parts and products of a consumable nature;
- Defects, damage or other conditions caused, in whole or in part, by mishandling, misuse, abuse, negligence, alteration, accident, freight damage, tampering or failure to seek and obtain repair or replacement in a timely manner;

- Products which are not installed, used, and properly cleaned and maintained as required in the UMF Medical installation and/or Owner's Manual for the applicable product;
- Replacement parts, alterations or installation of any accessories or parts not manufactured or recommended by UMF Medical;
- Cosmetic and non-functional defects not noted at time of delivery.
- Charges for repairs, replacement parts, adjustments, installation or other work performed upon or in connection with products which are not expressly authorized in writing in advance by UMF Medical.
- Damages resulting from inadequate power supply (including incorrect voltage, voltage spikes or other irregularities) or use or storage in corrosive atmospheres.

To the extent any or all of the following exclusions or provisions of this warranty are prohibited by any federal, state, or municipal law which cannot be preempted, those exclusions or provisions shall not be applicable.

Exclusive Remedy: Consequential Damages Disclaimer

UMF Medical's only obligation under this warranty is the repair or replacement of defective parts. UMF Medical shall not be liable for and hereby disclaims any direct, special, indirect, incidental, exemplary or consequential damages or delays, including but not limited to, damages for loss of profits or income, loss of use, downtime, employee or independent contractor wages, payments and benefits, commercial loss or other incidental charges.

No Authorization

No person or firm is authorized to create or approve for UMF Medical any other obligation or liability in connection with the products.

Warranty Disclaimer

THIS WARRANTY IS UMF MEDICAL'S ONLY WARRANTY AND IS IN LIEU OF ALL OTHER WARRANTIES, EXPRESS OR IMPLIED. UMF MEDICAL MAKES NO IMPLIED WARRANTIES OF ANY KIND INCLUDING ANY IMPLIED WARRANTIES OR MERCHANTABILITY OR FITNESS FOR A PARTICULAR PURPOSE. THIS WARRANTY IS LIMITED TO THE REPAIR OR REPLACEMENT OF DEFECTIVE PARTS.

No action may be brought against UMF Medical for breach of this limited warranty, an implied warranty, if any, or for any other claim arising out of or relating to the products following expiration of the limited warranty period.

UMF Medical reserves the right to make changes in the design or material of its products without incurring any obligation to incorporate such changes in any product previously manufactured.

III. Salient Characteristics

a. High-low function

The high-low function of the 4040/4070 Power Exam Table allows for easy height adjustment in infinitely adjustable increments. By using simple controls, the table can be raised or lowered from a low height of 18.5" (46.9cm) to a maximum height of 37" (93.9cm) at the seat to accommodate different needs. This feature reduces strain on medical practitioners and provides comfort for patients during examinations.

b. Easy-clean powder coated base

The 4040/4070 Power Exam Table with powder coat enamel surfaces offers several advantages when it comes to ease of cleaning. The smooth and non-porous nature of the enamel surface makes it resistant to stains, dirt, and bacteria, as it prevents liquids and contaminants from penetrating the surface. Additionally, the durable finish of powder coat enamel ensures that the surface remains intact even after repeated cleaning and disinfection, avoiding the accumulation of bacteria.

While the powder coated enamel surfaces facilitate easier cleaning, it is still important to follow proper cleaning and disinfection protocols in healthcare settings to maintain a high standard of hygiene.

c. Power back function (4040 models only)

The 4040 Power Exam Table with power back can be activated using a wired or wireless hand control, or a wired or wireless foot control, depending on the model and options chosen. The power back function assists clinical staff in lying back and sitting up patients as needed for exams and procedures. This keeps staff from having to strain to help patients and reduces the chance of injury for staff and patients.

d. Manual back function (4070 Series only)

The 4070 Power Exam Table with manual back can be activated using the hand lever located on either side of the back rest. By pulling the lever, clinical staff can adjust the position of the backrest as needed for exams or procedures.

e. Low ADA table height

According to the Americans with Disabilities Act (ADA), an accessible exam table or chair should have the ability to lower to the height of a wheelchair seat, 17-19 inches from the floor.

The 4040/4070 Power Exam Table provides low, ADA height for ensuring accessibility and facilitating patient care, especially for individuals with disabilities. ADA-compliant seat heights on exam tables facilitate patient transitions, making it easier for patients to get on and off the table, enhancing their overall experience during examinations or procedures. Individuals with mobility disabilities often require adjustable-height tables, allowing them to access medical care comfortably when positioned at a low height.

f. Foot control

The 4040/4070 Series Power Exam Table (all models) includes a foot control with power hi-lo buttons that allow the table to move from low, ADA height to full extended height. The power backrest up and down buttons (4040 models only) allow the table to be positioned anywhere from flat to upright seated positions.

g. Weight capacity

The weight capacity of the 4040/4070 Power Exam Tables is 650lbs., allowing the tables to easily accommodate patients of all sizes.

h. Stirrups

The 4040/4070 Series Power Exam Tables with stirrups offer clinical staff the flexibility to easily adjust and position patients according to the specific requirements of various medical examinations, ensuring optimal visibility and access to the treatment area.

These foldaway stirrups, with adjustable length, friction lock solidly into place and can be arranged in four lateral positions.



- 1 Pull the stirrups out and unfold.
- 2 Lift slightly and move left or right to position.
- 3 Release stirrup to lock into position.

WARNING: DO NOT SUPPORT THE PATIENT'S ENTIRE WEIGHT WITH THE STIRRUPS.

i. Drawer warmer

The front drawer warmer on the 4040/4070 Power Exam Tables (-300 models only) keeps instruments and tools at a comfortable temperature for use on a patient. With a power switch built into the front of the table, the drawer warmer helps ensure instruments are ready for use and provides added convenience for healthcare professionals, eliminating the need to retrieve tools from a separate warming source.



- 1 Press switch to power on and off.

j. Stainless steel drip pan

The 4040/4070 Series Power Exam Tables (-300 models only) include a removable drip pan for collecting fluids, preventing spillage onto the floor or patient, and maintaining a clean and hygienic environment in the exam room. The stainless-steel material provides for easy cleaning and disinfection after each use.



- 1 Slide the leg section out.
- 2 Lift front of the leg pad to disengage from locked position.
- 3 Slide leg pad toward rear of table.

WARNING: DO NOT USE THE LEG REST TO SUPPORT PATIENT'S ENTIRE WEIGHT.

The 4040/4070 Power Exam includes a pelvic tilt feature, which serves a crucial purpose in medical examinations. It allows healthcare professionals to adjust the angle of the patient's pelvic region, providing better access and visibility during various examinations that require access to the pelvic area. The ability to modify the pelvic angle enhances patient comfort and allows for a more comprehensive assessment, making this power exam table a versatile and functional tool in medical settings.

k. Pelvic tilt



- ① Lift up seat section and flip the pelvic support arm.
- ② Place seat section down to secure the mechanism.

l. Tamper-Resistant electrical receptacle

The 4040/4070 Power Exam Tables are equipped with tamper-resistant electrical receptacles, ensuring enhanced safety during medical examinations. These receptacles are designed to reduce the risk of electrical shocks and enhance protection for patients and medical professionals.

The tamper-resistant feature prevents the insertion of foreign objects into the receptacles, providing a crucial safety measure in healthcare environments where electrical equipment is prevalent. This aligns with industry standards and guidelines for electrical safety in medical settings.

m. Paper roll holder

The paper roll holder on the 4040/4070 Series Power Exam Tables holds a standard size disposable exam paper roll, which provides a protective barrier between the patient and the exam surface.



Max Roll Size
21" x 3.5" (53cm x 9cm)

Slide rod out of brackets, install new roll, and reinstall into brackets

IV. Environmental Conditions

The 4040/4070 Power Exam Table operates optimally within the following environmental conditions.

- TRANSPORT/STORAGE TEMPERATURE: -20°C to 40°C
- TRANSPORT/STORAGE/OPERATING HUMIDITY: 95% maximum
- OPERATING TEMPERATURE: 0°C to 40°C

V. Specifications

4040-650

Maximum Patient Weight	650 lbs (295kg)
Net weight	470lb (213kg)
Shipping weight	510lb (231kg)
Shipping dimensions	L 64" x W 30" x H 31" (163cm x 76cm x 79cm)
Electrical Supply (Standard)	120V 60HZ 9AMP
Electrical Supply (Optional)	220V 60HZ 5AMP
Power Cord Length	10 FT (3.0m)
Table Weight	400lbs (181kg)
Paper Roll (Maximum size)	L 21.0" x D 3.5" (53.3cm x 8.9cm)
Storage Drawer (Front)	W 19.0" x D 12.0" x H 3.5" (48cm x 30cm x 9cm)
Storage Drawer (Side)	W 24.5" x D 12.5" x H 3.5" (62cm x 32cm x 9cm)

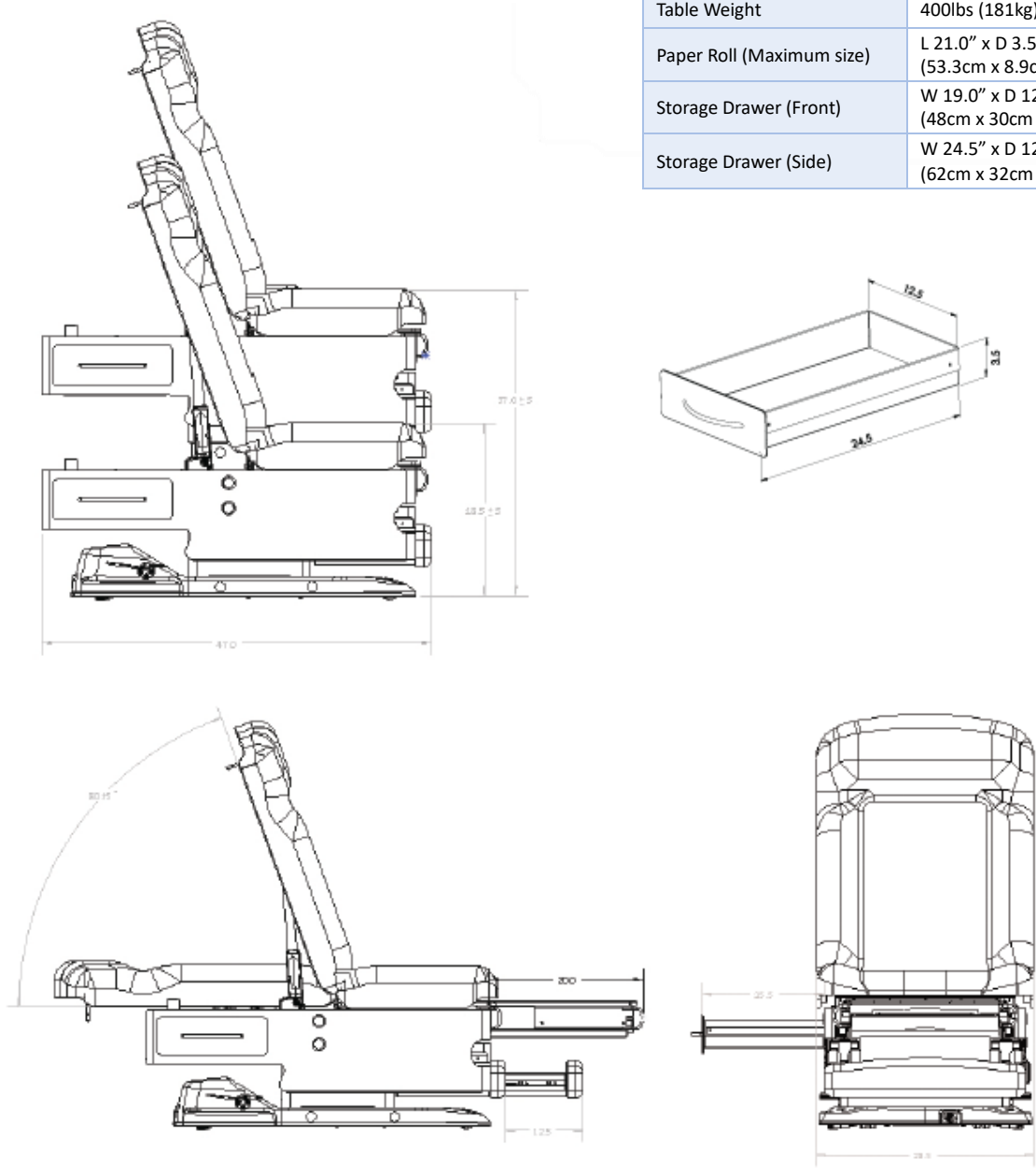

4070-650

Maximum Patient Weight	650 lbs (295kg)
Net weight	470lb (213kg)
Shipping weight	510lb (231kg)
Shipping dimensions	L 64" x W 30" x H 31" (163cm x 76cm x 79cm)
Electrical Supply (Standard)	120V 60HZ 9AMP
Electrical Supply (Optional)	220V 60HZ 5AMP
Power Cord Length	10 FT (3.0m)
Table Weight	400lbs (181kg)
Paper Roll (Maximum size)	L 21.0" x D 3.5" (53.3cm x 8.9cm)
Storage Drawer (Front)	W 19.0" x D 12.0" x H 3.5" (48cm x 30cm x 9cm)
Storage Drawer (Side)	W 24.5" x D 12.5" x H 3.5" (62cm x 32cm x 9cm)

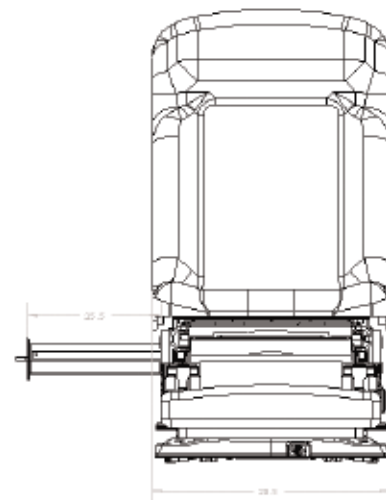
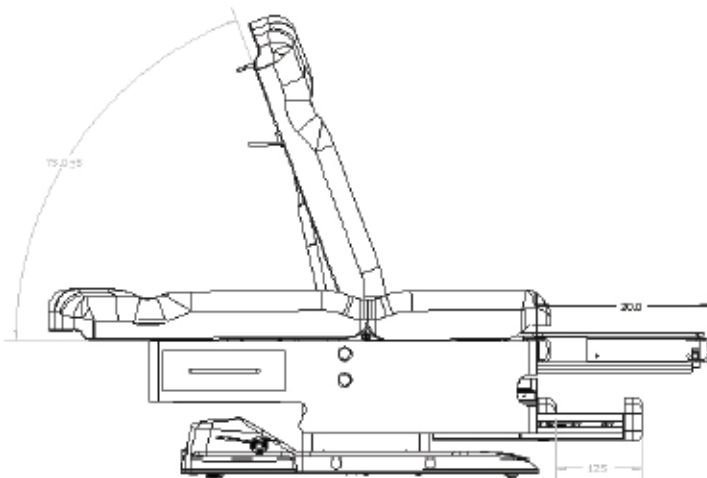
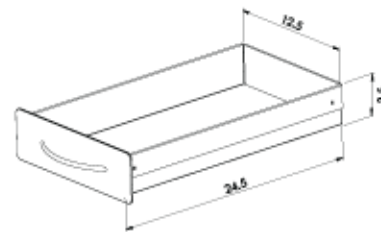
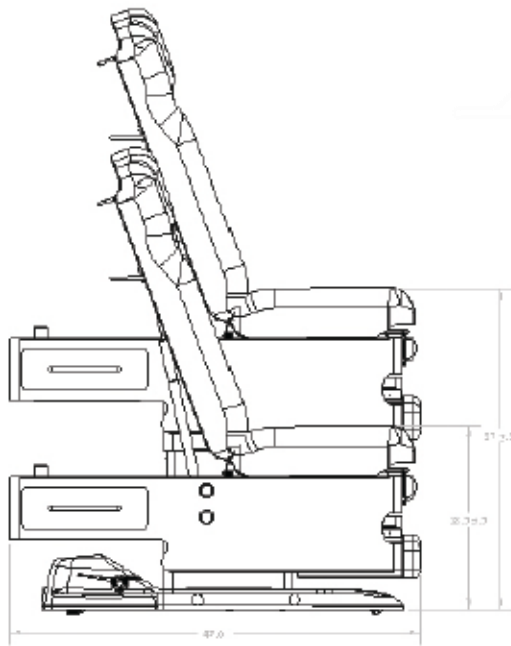

Patient Safety Table Lockout



This table is equipped with a safety feature that allows the practitioner to deactivate all table functions in order to prevent misuse when staff is not present.

To lock and unlock:	Press & hold STOP button for 2 seconds.	1 beep indicates locked 2 beeps indicates unlocked
---------------------	---	---

WARNING: FOR MAXIMUM PATIENT SAFETY, LOCK TABLE IMMEDIATELY AFTER EACH USE

VI. Equipment Care

Care of upholstery

The upholstery material used on the top, leg rest, and headrest is resistant to most medical stains.

For light cleaning:

- 1 A solution of 10% liquid soap and clean water applied with a soft damp cloth will remove disinfection cleaner build-up.
- 2 If necessary, a solution of liquid cleanser and water can be applied with a soft bristle brush. Wipe away residue with a water-dampened cloth.

For disinfection:

- 1 Dampen a soft white cloth with a solution of standard bleach (sodium hypochlorite) or other chlorine-based cleaner*** and water; 10% bleach, 90% water.
- 2 Rub gently.
- 3 If necessary, allow the 1:10 diluted bleach (sodium hypochlorite) solution to puddle on the affected area or apply with a clean, soaked cloth for approximately 30 minutes. Rinse with a water-dampened cloth to remove any remaining bleach concentration.
- 4 Rinse with a water-dampened cloth to remove cleaner solution and allow thorough drying of material.

***See current CDC Guideline for Disinfection & Sterilization in Healthcare Facilities for bleach alternative cleaners.

Note: Immediately remove any fluid spilled on upholstery surface.

Antimicrobial: UMF Medical Upholstery provides outstanding protection in difficult medical and healthcare environments and contains an agent effective against bacterial and fungal microorganisms.

Care of painted surfaces

A chemical acid-resistant paint is used, but extreme care must be taken not to use ammonia-based cleaners or discoloration of paint may occur. A damp cloth or mild liquid soap solution should be sufficient.

Care of bright metal surfaces

All non-painted surfaces, chrome plated, or stainless steel should be wiped weekly with a clean damp cloth then buffed to a lustrous shine with a soft dry cloth.

Care of base

The protective base is easily washable with mild liquid soap and water. A soft bristle brush may be used on scuffed or stained areas.

CAUTION: WHEN THE USE OF STRONG CLEANING SOLUTIONS IS NECESSARY, TEST AN INCONSPICUOUS AREA TO ASSURE THAT DAMAGE TO UPHOLSTERY OR PAINTED SURFACES WILL NOT OCCUR.

QUESTIONS, COMMENTS OR SERVICE REQUESTS

Contact:

UMF Medical Customer Service
1316 Eisenhower Blvd
Johnstown, PA 15904

Toll Free: 1(800) 638-5322
Email: customerservice@umfmedical.com
Fax: 1(814) 266-1870

* For service requests, please have model % serial number available.

VII. Care and Cleaning

Exam Table Upholstery with PreFixx® Protective Finish

Helping to enhance infection prevention initiatives

In laboratory testing, upholstery protected with PreFixx® finish was treated with the following disinfectants with little to no discoloration or damage to the upholstery. This testing may not reflect actual results in the field.*

Recommended Disinfectants**

- › Ecolab Quaternary Disinfectant Wipes
- › Agar™ Powerquat
- › Asepticare™
- › Asepticare™ TB-II
- › AVISTAT-D™ Ready To Use Spray Disinfectant Cleaner
- › Biotrol BirexSE®
- › Bleach 1:5 (20% bleach)
- › Bleach 1:9 (10% bleach)
- › Bleach-Rite® Disinfecting Spray
- › CaviCide™
- › CaviCide1™
- › CaviCide™ AF
- › Clorox® Broad Spectrum Quaternary Disinfectant Cleaner
- › Clorox® Healthcare Bleach Germicidal Cleaner
- › Clorox® Healthcare Bleach Germicidal Wipes
- › Clorox® Healthcare EZ-KILL® Wipes
- › Clorox® Healthcare VersaSure® Cleaner Disinfection Wipes
- › Clorox® Hydrogen Peroxide Cleaner Disinfectant Spray
- › Clorox® Hydrogen Peroxide Cleaner Disinfectant Wipes
- › Diversey™ Accel® INTERvention® Wipes
- › Diversey™ Avert® Sporicidal Disinfectant Cleaner
- › ERC Performance Wipes
- › McKesson Disposable Germicidal Surface Wipes
- › McKesson Pro-Tech RTU Disinfectant Cleaner
- › OPTIM® 1 Wipes
- › OPTIM® 33TB
- › Oxivir® 1 RTU
- › Oxivir® Five 16
- › Oxivir® TB
- › OxyCide™ Daily Disinfectant Cleaner
- › PDI Sani-Cloth® AF3 Germicidal Disposable Wipes
- › PDI Sani-Cloth® HB
- › PDI Sani-Cloth® Plus
- › PDI Sani-Cloth® Prime Germicidal Disposable Wipe
- › PDI Super Sani-Cloth®
- › PDI Super Sani-Cloth® Bleach Germicidal Disposable Wipes
- › Precise QTB Spray
- › PROCHEM® Oxy Plus
- › Purell® Healthcare Surface Disinfectant
- › Purell® Multi-Surface Disinfectant
- › Sani Professional® Cleaning + Degreasing Multi-Surface Wipes
- › Sani Professional® Multi-Surface Cleaning Wipes
- › Sani Professional® No-Rinse Sanitizing Multi-Surface Wipes
- › SaniZide® Plus
- › STERI-7 XTRA CONCENTRATE (recommended dilution ratio 1:10)
- › STERI-7 XTRA WIPES
- › Vert-2-Go ED
- › Virox AHP 5
- › Virox PREempt™ RTU
- › Virex® II 256
- › Virex® Plus One-Step Disinfectant Cleaner & Deodorant
- › Wayne® Concept 256N
- › Wex-Cide 128

*All disinfectants and cleaning agents contain chemicals that degrade coated fabric upholstery to some extent. To promote a long product life, it is recommended that the PreFixx cleaning and maintenance protocol be employed regularly.

**Recommended disinfectants are only recommended when following the disinfectant manufacturer's instructions for application, and inclusion in this document does not imply "fit for use." Customers should first determine if products are appropriate for use on their surfaces.



Care & Cleaning

Use one of the following cleaners with a soft cloth or damp sponge. Rinse area with fresh water then dry with a clean, lint-free cloth.

Primary

Recommended Cleaner

- › Formula 409 All-Purpose spray cleaner
- › Fantastik spray cleaner

Secondary

Recommended Cleaners

- › Lysol Clean and Fresh Multi-Surface Cleaner (Reckitt Benckiser)
- › Lestoil Heavy Duty Cleaner (Clorox)
- › Mr. Clean / Flash Clean and Shine (Procter and Gamble)
- › Eco Touch All Purpose Premium Care

For more difficult stains, contact UMF Medical Customer Service.